

PRESSURE VACUUM GAUGE

Model 131 Series



FEATURES

- Stainless steel body and mounting threads.
- UV stabilized poly-carbonate lens.
- Suitable for both indoor and outdoor applications.
- $\pm 2\%$ accuracy in middle half of the range.
- Highly visible white marking on black background.
- Meets or exceeds ANSI standards for transformer.

VIAT

INSTRUMENTS

CA131-2R0



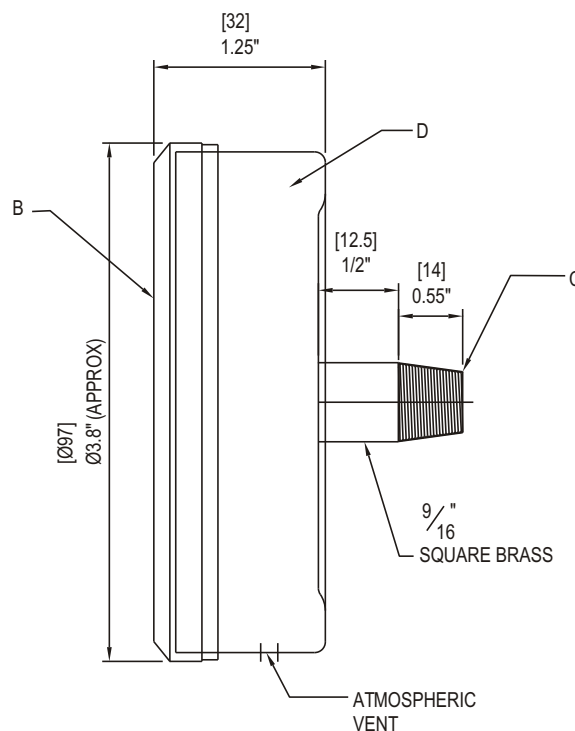
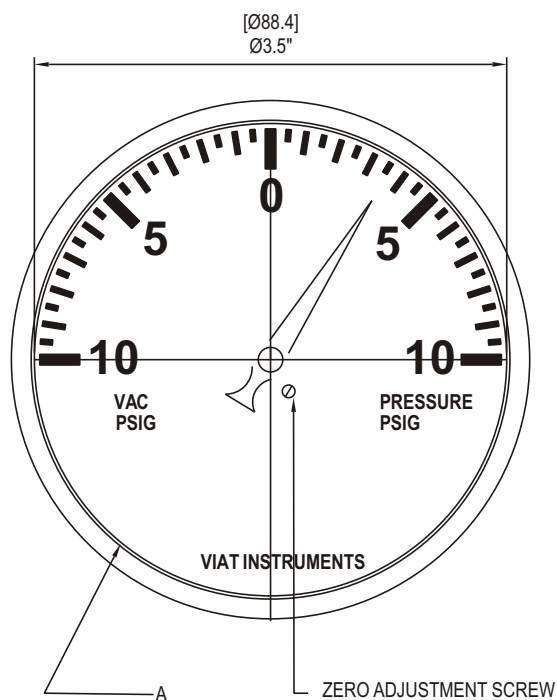

PART NO.	QTY	DESCRIPTION	MATERIAL
A	1	DIAL	ALUMINIUM
B	1	LENS	UV PROTECTED POLYCARBONATE
C	1	MOUNTING THREAD ¼ NPT	BRASS
D	1	CASE	STAINLESS STEEL

DESCRIPTION

The VIAT pressure vacuum gauges are designed for use in transformers both for indoor and outdoor applications. The casing as well as mounting threads are of stainless steel. All internal mechanisms are corrosion resistant for prolonged maintenance free service. A breather hole at the bottom of the case prevents condensation of moisture on the lens.

OPERATION

The VIAT pressure vacuum gauges are designed to measure and indicate pressure in the range of +10 PSIG to -10 PSIG. A bourdon tube senses the pressure changes and transfers movement through a gear drive to the pointer.

The removable lens allows zero adjustment if necessary, after the gauge has been mounted on the tank.

Due to our policy of continuous product improvement, dimensions and designs are subject to change.



VIAT INSTRUMENTS PVT. LTD.

2701 to 2704, Shilpangan Phase-II, Block LB-1
Sector-III, Salt Lake, Kolkata - 700 098, INDIA
Phones : (91-33) 9903805104, 23352925 ● Fax : (91-33) 23352926
E-mail : viatin@viatin.com ● Website : www.viatin.com

VIAT AMERICA, INC.

30 Shepard, Irvine, CA 92620
Tel: 949-679-0950 Fax: 949-417-1358
E-mail : sales@viatamerica.com
Website : www.viatamerica.com